

1. TECHNICAL SPECIFICATIONS

Power: AC120V (60Hz)

Rated Load: ≤103W

The up/down limit can easily be set through the external limit setting device WSB11 or push button on the motor head. This motor can be connected with the external manual switch. It can also work with remote control system, which is equivalent to the use of standard type motor. When the motor works with remote control system, the wire connection is shown in the specification of adaptive remote control system.

Description and specifications given in this introduction are subject to modification with notice. If there is any change on the appearance and color, please refer to real objects.

2. WIRE CONNECTION

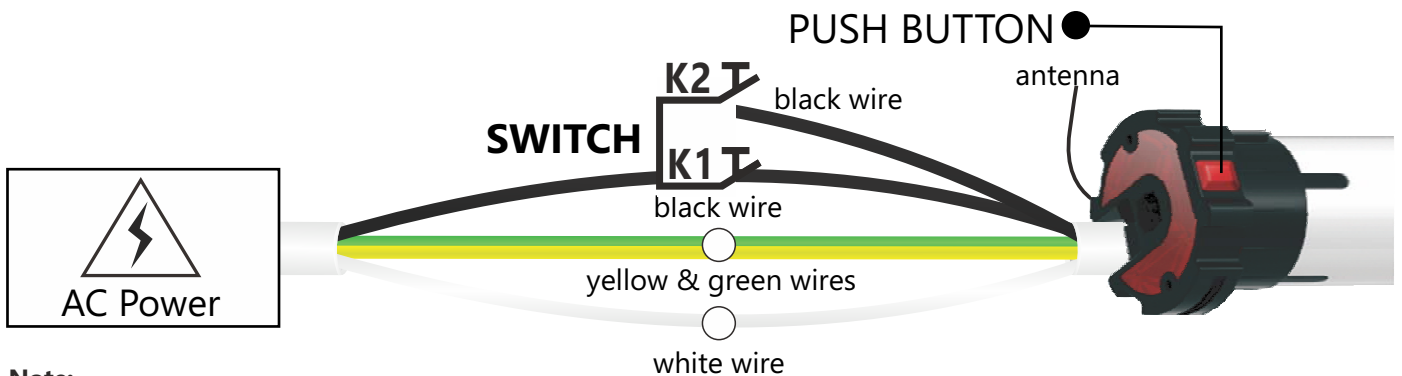

Note:

The black wire of the motor should be connected to the brown wire from power supply through the switch K1 and K2. The blue wire should be connected to the blue wire from power supply. The ground wire should be connected to the ground wire from power supply. When the switch K1 is closed, motor goes up. When the switch K1 is cut, motor stops. When the switch K2 is closed, motor goes down. When the switch K2 is cut, motor stops. The limits can be set easily through the external limit setting device WSB11 or push button.

3. WSB11 WIRE CONNECTION

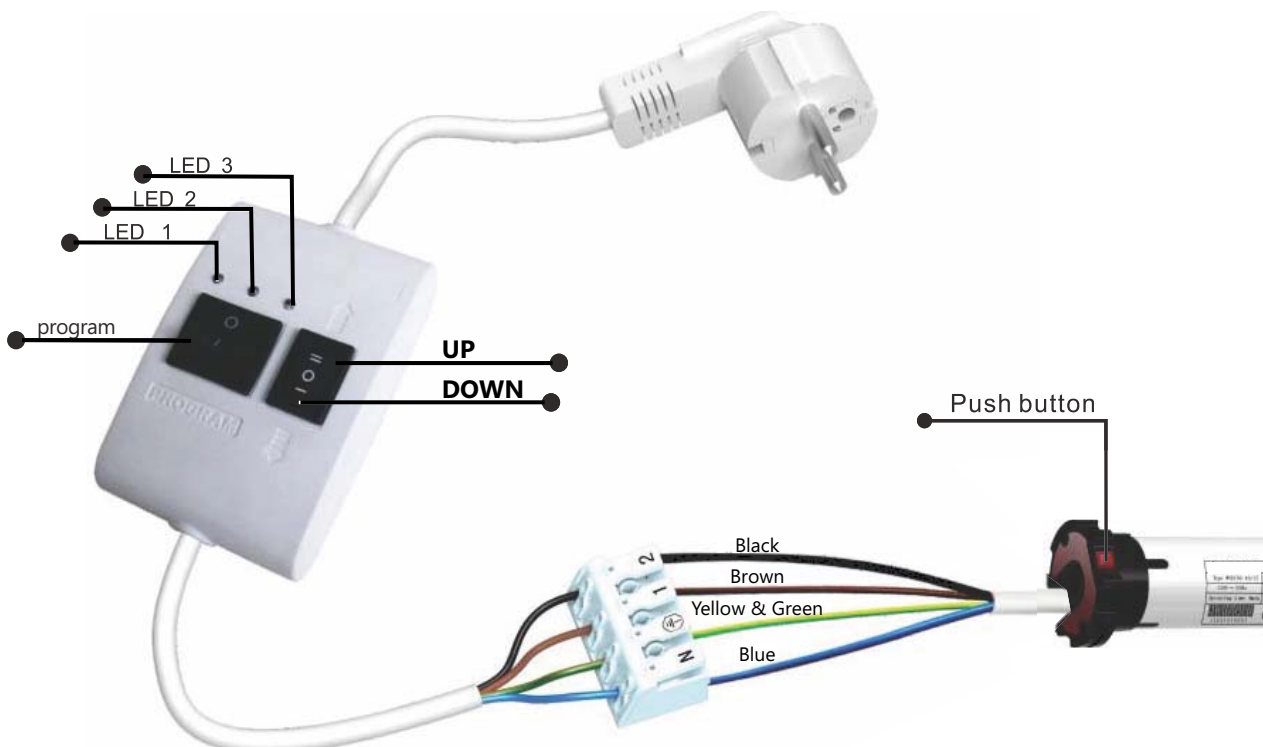

Notes: When UP/Down/Program button is pressed, light LED1 is on. When Program button is pressed for 2s, light LED2 is on. When Program button is pressed for 10s, light LED2 is off and LED3 is on.

4. LIMIT SETTING THROUGH PUSH BUTTON

Up limit setting



When switch K1 is closed, the motor goes up. Long press the button on the motor head.

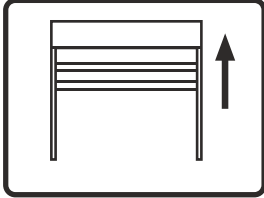

Release the button when the motor arrives at the position you want. The stop position is the up limit (You can set the limit in the same way till the limit at your wanted position)

Down limit setting



When switch K2 is closed, the motor goes down. Long press the button on the motor head.

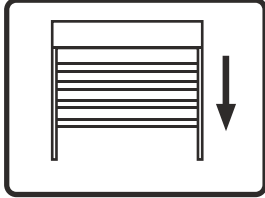

Release the button when the motor arrives at the position you want. The stop position is the down limit (You can set the limit in the same way till the limit at your wanted position)

5. LIMIT SETTING THROUGH WSB11

Up limit setting



1) long press the Up button till the motor arrives at the position you want.

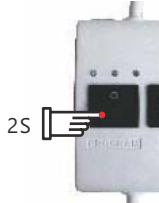

2) Long press the Program button for 2 s Then release the button till LED2 is on.



3) Long press the Up button again for 2 s and release the button. The up limit is set.

Down limit setting



1) long press the Down button till the motor arrives at the position you want.



2) Long press the Program button for 2 s Then release the button till LED2 is on.



3) Long press the Down button again for 2 s and release the button. The down limit is set.

6. LIMIT DELETING

Way A



Long press for 10 seconds

Long press Program button for 10s (LED3 is on). Both up and down limits are deleted.

Way B

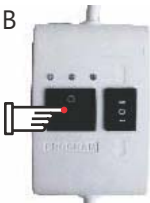

Long press for 2 seconds



x1



Long press for 2 seconds



x1

1) When the motor stops running, long press the Program button for 2s and then release. 2) Press Up button once. 3) Press Program button for 2s and then release. 4) Press Down button once. Both up and down limits are deleted.

Note: The button press should be about 2s with 5s interval. During the set-up, there might be interference from other signals which leads to the failure. Please reset up.