

RC 007 Instruction

10 Troubleshooting

Type of fault	Remedy
Transmit LED of the emitter does not light up	Check the battery in the emitter
No reaction after signal sent	Check the power and wire connection. Check if the temperature is normal. (-10...+55°C)
The remote distance becomes shorter.	Please change the battery or check if there are interference around.
Emitter is OK and the signal cannot be sent.	Check the power and the program setting.

1 Safety Notes

1. Keep away from children to avoid any possible damage to the receiver caused by their play.
2. If the supply cord is damaged, it must be replaced by the manufacturer, the service agent or similarly qualified electric technicians in order to avoid a danger.
3. The receiver is of high voltage. Keep it away from the water.
4. The installation pole is fixed the installation board. Please be careful during the installation.

2 Technique Specifications

Receiver :

- Power: AC 230V/50Hz, 110V/60Hz
- Rated load: ≤ 1600W
- Lighting Output: ≤ 500W
- The receiver will be power-off automatically after working for 3mins continuously
- The receiver can be controlled by 15 emitters at most
- Fuse rated currency: 8A

3 RC 007 Wire Connection

The wiring is taken 230V/50Hz as an example. For 120V / 60Hz, please refer to the corresponding standard.

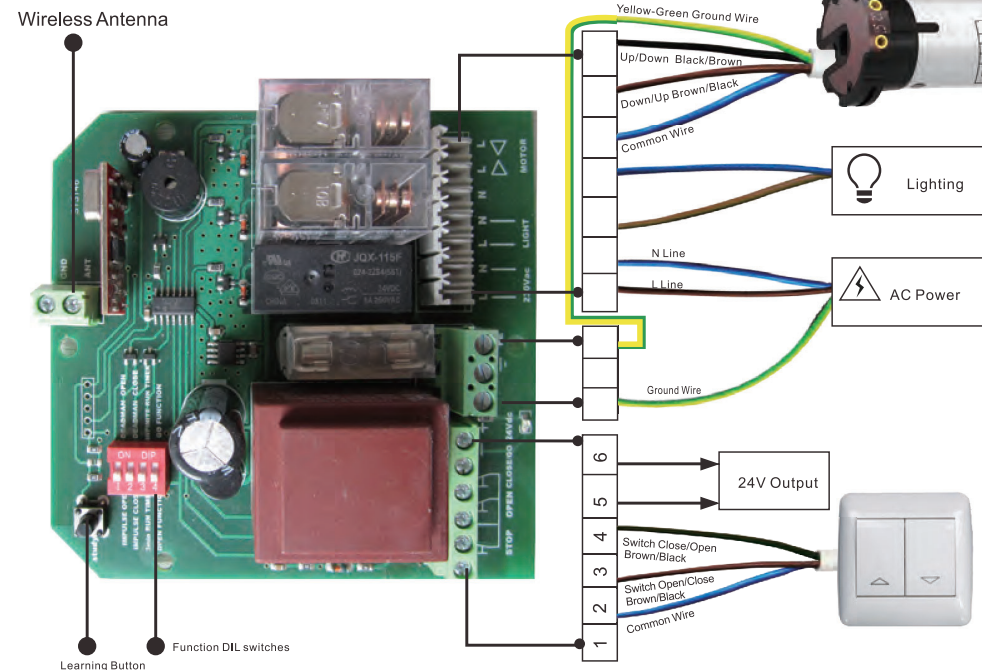

RC 007 Instruction

4 Terminal Instruction

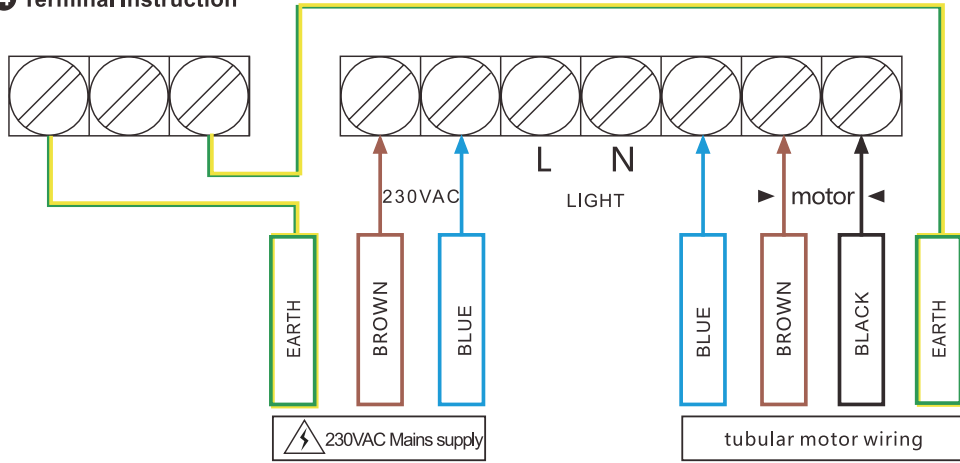

1)Pls refer to the above instruction for wiring.

2)If the tubular motor runs in opposite direction, pls exchange the brown and black wire.
Note: Tubular motor's power is 1600W.

3)A light can be wired at the "LIGHT" terminal if required.The "RUN TIMER" switch controls the light's running time.
Note: The light's power should be under 500W.

Program Setting

Note: We take WSRE010 as example.For any other emitter produced by our company, please follow the same instruction. The following "Short press" means more than 0.5s, and "Long press" means more than 3s. The interval between every pressing should be at least 1s. There maybe other signal interference to cause setting to fail. Please set again.

5 Code Learning

Note: After code learning, you can use the emitter to control the tubular motor through up,stop and down button.

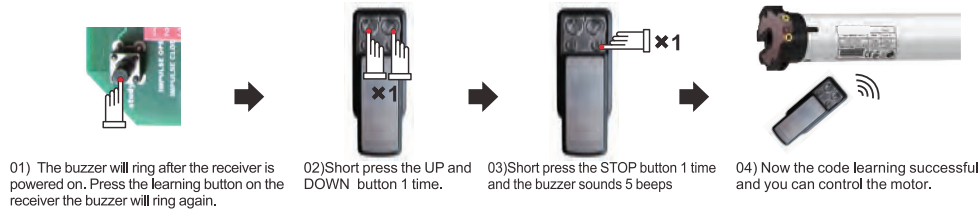

6 Copy Note: After copy, the new emitter can control the motor as well.

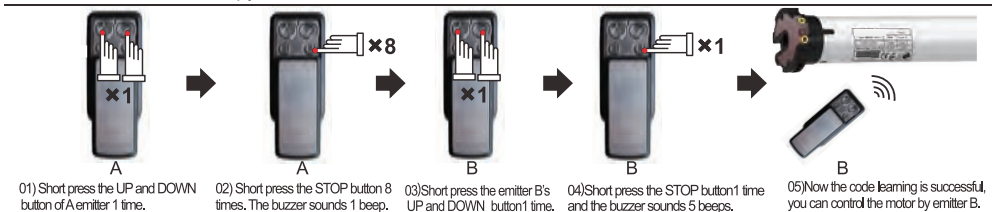

7 Code Deleting

WayA



Long press the learning button on the receiver, the buzzer will ring once, and then ring again twice 2s later, now release the button, the code is deleted. All emitters that have learned receiver's code can't control this receiver.

WayB

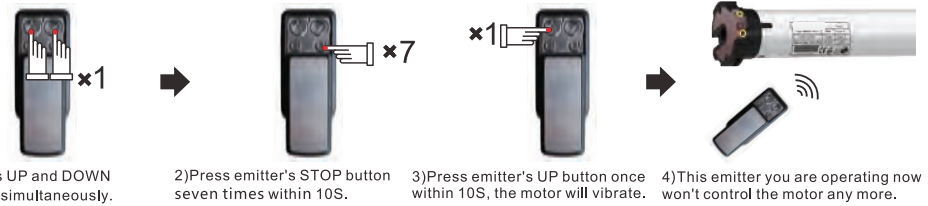

WayC

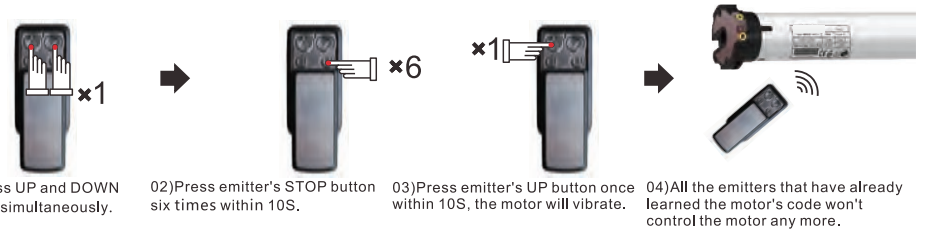

8 DIL Switch Functions

- DIL1
 - IMPULSE OPEN - tubular motor runs upwards continuously.
 - DEADMAN OPEN - tubular motor runs upwards from point to point.
- DIL2
 - IMPULSE CLOSE - tubular motor runs downwards continuously.
 - DEADMAN CLOSE - tubular motor runs downwards from point to point.

- DIL3
 - 3 min RUN TIMER - the light will be off after working 3 minutes.
 - INFINITE RUN TIMER - the light works all the time.

- DIL4
 - OPEN FUNCTION - wall switch connects to terminal 2 and 3, the motor will run upwards. wall switch connects to terminal 2 and 4, the motor will run downwards.
 - GO FUNCTION - wall switch connects to terminal 2 and 4, the motor can run upwards, downwards and stop running.

9 Other Auxiliary Connections

A.wiring for obstacle-stop function.

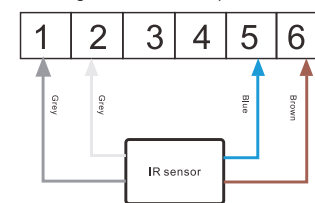

B.wiring for obstacle-rebound function

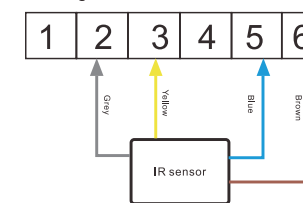

C. wiring for manual switch

