

RC 006 Instruction

1 Technique Specifications

Receiver :

- Power: AC 220V / 50Hz(AC110V/60Hz)
- Rated load: do not exceed 400W
- Protection Index: Ip44
- The receiver can be compatible with 15 emitters at most
- The receiver will cut off electricity after working 4 minutes continuously

2 Wires Connect

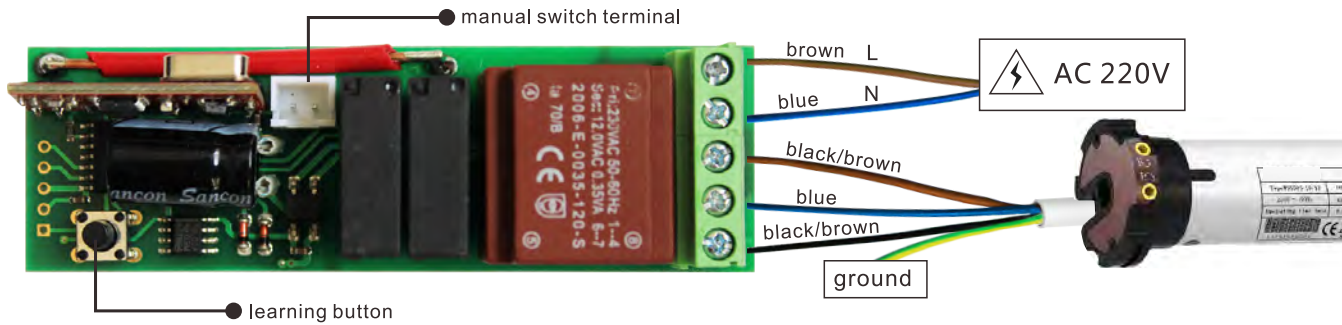

3 Code Learning

Way A

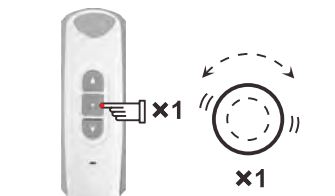
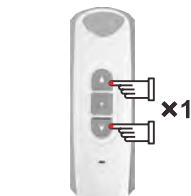

Way B

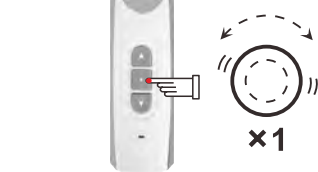
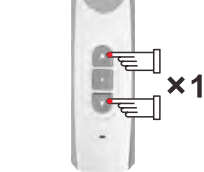
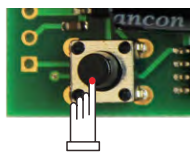

4 Copy Note: Emitter B can control the tubular motor after it learns code from emitter A.

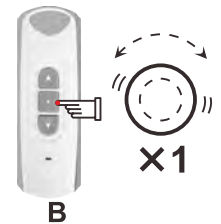
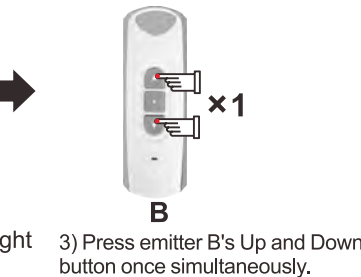
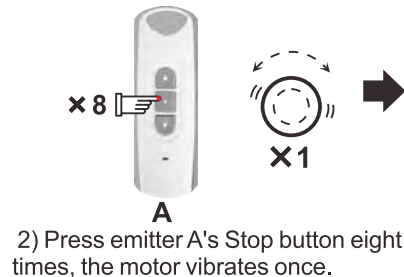
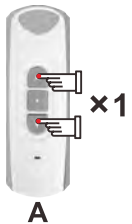

5 Code Deleting Note: No emitter can control this tubular motor after code deleting unless you reset.

Way A

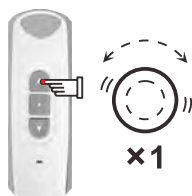
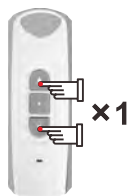

RC 006 Instruction

Way B

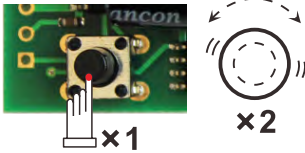

Press the receiver's learning button till the motor vibrates 2 times.
The code is deleted and no emitters can control this motor.

Way C



1) Press emitter's Up and Down button once simultaneously.

2) Press emitter's Stop button seven times.

3) Press emitter's Up button, the motor vibrates once.

4) The emitter you are operating is deleted and can not control the motor.

6 Direction Change

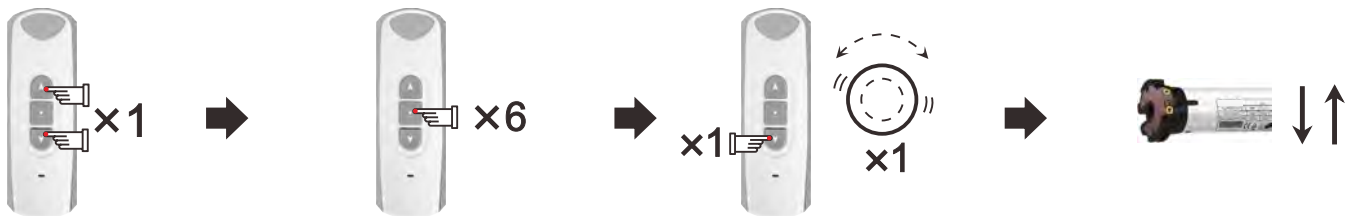

1) Press emitter's Up and Down button once.

2) Press emitter's Stop button six times.

3) Press emitter's Down button once, the motor vibrates.

4) The motor's running direction is changed.

7 Set Step by Step Function

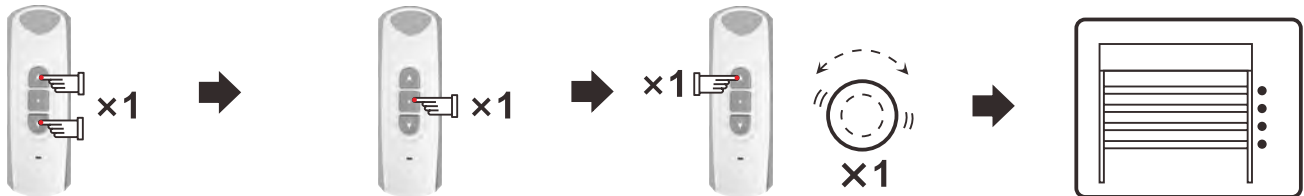

1) Press emitter's Up and Down button once.

2) Press emitter's Stop button once.

3) Press emitter's Up button once, the motor vibrates once.

4) The motor will run step by step.

If the motor is in vibration state, press emitter's Up or Down button for 3 seconds, the motor will run continuously. Press the Stop button, the motor will change into vibration state.

8 Delete Step by Step Function

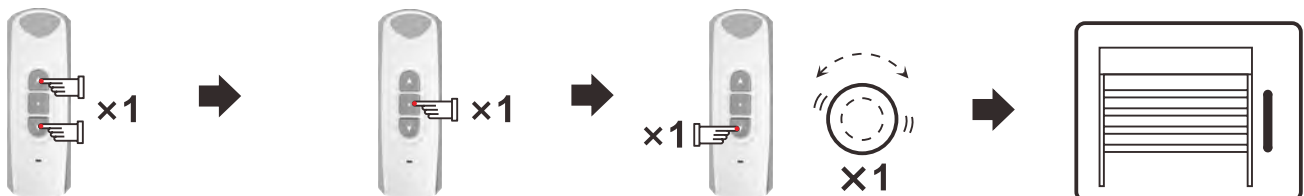

1) Press emitter's Up and Down button once.

2) Press emitter's Stop button once.

3) Press emitter's Down button once, the motor vibrates once.

4) The motor will run continuously.

9 Wall Switch

A wall switch can be connected to the receiver to control the tubular motor. The manual switch is to connect Door Bell Switch. With manual switch, the tubular motor could achieve Up-Stop-Down-Stop-Up... sequence.

! Announcement

- The setting may fail due to other signal interference. In this case, please reset.
- The emitter RE101 is taken as an example in this instruction. The receiver is compatible with other rolling codes emitters too.
- If emitter's battery is in low power, please replace it.
- The receiver is of high voltage, please do not place it in humid atmosphere.
- Children should be supervised to ensure that they do not play with the appliance.
- Working temperature: $-10^{\circ}\text{C} \sim +55^{\circ}\text{C}$.
- All products are as per real subjects. There will be no prior notification if any change in appearance, color, functions etc.